

SGA

Si mi n G a m a n A r i a

www.sga-safety.ir

SFD-1000 Installation Manual

Be
Different.



Safety Cautions:

- It is necessary to install and operate only informed and trained people.
- Before starting the installation operation, read this instruction carefully.
- Avoid opening the detector when it is power on in environments where there is a possibility of flammable gas.
- Before opening the detector, make sure it is power off.

Content

1	Introduction	4
2	Mechanical Features	4
3	Main Features	5
4	Ordering Numbers	6
5	False Alarm Immunity	6
6	Output Signals in Different Conditions	7
7	Detector Settings Adjustment:	7
8	Installation instruction	10
8.1	Swivel Mounting Bracket Installation	11
8.2	Installing Detector on Swivel Mounting Bracket	11
8.3	Opening Detector Head	11
8.4	Closing Detector Head.....	12
8.5	Adjusting Viewing Angle.....	12
9	Input and Output Terminals	13
10	Wiring Diagrams.....	14
10.1	Using Relays Wiring Diagram	14
10.2	Using Analog Output Wiring Diagram	15
11	Drawings and Dimensions	16
12	Functional Safety Cautions.....	18
12.1	Simin Gaman Aria Flame Detectors	18
12.2	Certified product identification of device	18
12.3	Applied Standards.....	18
12.4	Safety Parameters	19
12.5	Guidelines for configuring, installing, operating and service	19
12.6	Conditions for Safe Operation	19
12.7	Proof Test Procedure and Special Tools	20
12.8	Cleaning Procedure.....	20
12.9	Fault/failure action plan	21
12.10	Product repair	21
12.11	Decommissioning and disposal	21
12.12	Vocabulary table of IEC61508.....	21

1 Introduction

Flame detector model SFD-1000 is designed and manufactured for fast detection of the flame and prevent its spread in industrial, workshop environments, using ultraviolet and infrared sensors with false alarm rejection technology.

This text is used to guide the installation, operation, maintenance and repair of the flame detector model SFD-1000

2 Mechanical Features

- 1) Body Material:
 - Aluminum (Epoxy-Coated)
 - Stainless Steel (Optional)
- 2) Body Color: Red
- 3) Dimension:
 - Without Bracket: 127(W) x 127(H) x 167.5(D) mm
 - With Bracket: 442(W) x 127(H) x 167.5(D) mm
- 4) Weight:
 - Aluminum with mounting Bracket 2 KG
 - Stainless Steel with mounting bracket 5 Kg

3 Main Features

- 1) Sensor:
 - Ultra-violent: 185-260 nm
 - Infra-red: 4-4.6 μ m
2. Detection Distance: 25 meters for 0.1 m² Standard n-Heptane fire
3. Field of View (FOV): Vertical and Horizontal 100°
4. Response Time:
 - Operating <5 sec 0.1 m² Standard n-Heptane pan fire @ 25 meters
 - According to EN54-10 <30 sec 0.1 m² Standard n-Heptane pan fire @ 25 meters
5. Automatic Built-in Test: (Voltages, Sensor, window, Electronic Circuits & Software)
6. Signals:
 - Dry Contact:
 - Alarm Relay: 7A 230 VAC
 - Fault Relay: 7A 230 VAC
 - 0-20 mA Analog Current Output (Source)
7. Operating Voltage: 18-30 VDC
8. Power Consumption:

Condition	UV/IR – SFD-1000-U	IR4 – SFD-1000-R
Normal Condition without Built-in Test Models	90 mA	50 mA
Normal Condition with Built-in Test Models	450 mA	450 mA
Alarm Condition	90 mA	90 mA

9. Cable Entry: 2xM20
10. Indicator:
 - Status LED:
 - Bi-color: Red and Green
 - Alarm LED Red
11. Accessories:
 - Flame Simulator: Model SFD-1000-SU
 - Sunshade: Model SFD-1000-SS
 - Swivel Mounting Bracket: SFD-1000-MB
12. Approvals:
 - ATEX: (II 2G Ex db IIC T6 Gb)
 - IECEX: (Ex db IIC T6 Gb)
 - Ingress Protection Rating: IP66
 - SIL2
13. Environmental Condition:
 - Operating Temp.: -20 ~ +60° C
 - Relative Humidity: 5 to 99% RH (Non-Condensing)

4 Ordering Numbers

SFD-1000-X-Y-T

SFD-1000	X: Sensor Type	Y: Body Material	T: Automatic BIT(SIL Approval)
	<ul style="list-style-type: none"> •U: UV/IR •R: IR4 •SU:UV/IR SIL Certified 	<ul style="list-style-type: none"> •A: Aluminum •S: SS 316 	<ul style="list-style-type: none"> •Y: Included •N: Not Included

Accessories:

- 1) Flame Simulator: Model SFD-1000-SU
- 2) Sunshade: Model SFD-1000-SS
- 3) Swivel Mounting Bracket: SFD-1000-MB

5 False Alarm Immunity

According to the method of detection and operation of the flame detector, there are various cases that may cause false alarms. The table below shows the safe distances of the SFD-1000 model detector against false alarm conditions:

Table 1: False Alarm Immunity Conditions

Item	Description	SFD-1000-U Immune at Distance (m)	SFD-1000-R Immune at Distance (m)
1	Direct or reflected sunlight	IAD	IAD
2	Arc welding DC (190 ± 20) A, 7014 rod	3	IAD
3	Grinding metal	1	IAD
4	Fluorescent lamp 35W * 2	IAD	IAD
5	Halogen lamp 1kW	IAD	IAD
6	Halogen lamp 500W	IAD	IAD
7	Radiation Heater 1.5kW with Fan	IAD	IAD
8	Radiation Heater 3kW	IAD	IAD
9	Incandescent light 300W	IAD	IAD
10	Mercury vapor lamp 175W	IAD	IAD
11	Sodium lamp 70W	IAD	IAD
12	Lit cigarette	IAD	IAD
13	Lit cigar	IAD	IAD
14	Match, Wood, Stick including flare up	1	1
15	Flashlight (MX 991/U, Pelican Stealth Lite 2460)	IAD	IAD
16	Video Projector Lamp	IAD	IAD

- IAD: Immune at any distance

6 Output Signals in Different Conditions

SFD-1000 model flame detector has the ability to send output signals in the following different types:

- Analog: 0-20 mA
- Relay: Alarm, Fault

The following table 2 shows different outputs in normal, fault and alarm conditions:

Table 2: Output Signals in different conditions

Item	Status	Status LED	Alarm LED	Alarm Relay	Fault Relay	Analog output
1	Warm-Up	Green, Red Flickers Alternately for 500ms	Red Flickers for 500ms	OFF	OFF	0 mA \pm 3%
2	Normal	Green Flickers once in 3s	OFF	OFF	OFF	4 mA \pm 3%
3	Fault	Yellow Flickers once in 1s	OFF	OFF	ON	0 to 1 mA \pm 3%
4	Pre-Alarm	Green Flickers once in 3s	Red flickers for 200ms	OFF	OFF	12 mA \pm 3%
5	Alarm	Green Flickers once in 3s	Red lights on	ON	OFF	20 mA \pm 3%

Note: Fault Recovery Procedure

In Case of Trouble 1, operator can follow clause 12.8 for window cleaning procedure.

7 Detector Settings Adjustment:

SFD-1000 flame detector can be adjusted in the following three parameters:

- Sensitivity (SW1-Switch Number 1 and 2)

The higher the sensitivity, the higher the flame detection speed and the flame detection distance. For example, if the detector is placed in front of Flare in the project and it causes a false alarm, it is possible to remove the false alarm by reducing the sensitivity. Flame detection sensitivity can be adjusted in the following four levels:

1. Higher Flame Detection Sensitivity
2. High Flame Detection Sensitivity
3. Medium Flame Detection Sensitivity
4. Low Flame Detection Sensitivity

Note: The factory default setting is Low sensitivity.

- Alarm Latching (SW1-Switch Number 3)

In accordance with the EN-54 standard, in case of an alarm, the flame detector can be reset only by cutting off the power supply. Reset procedure can be automatically or by cutting off the power supply in the following two options:

1. Latch: Reset by disconnecting and reconnecting the power supply of the detector
2. Non-Latch: Automatically resets and returns to normal condition at least one minute after the flame goes out

Note: The factory default setting is Latching Alarm

- Built-in Test or Self-test (SW1-Switch Number 4)

SFD-1000 is able to check operation of Sensors, cleanness of window, electronic circuits and software continuously as option if ordered by customer. If SFD-1000 is equipped with Built-in test there are 2 adjustments

1. With Built-in Test
2. Without built-in test

Mentioned adjustments will be done by Dipswitch SW1 according to Figure 1 and Table 3

- Relay Alarm Energize / De-energize (SW2 – Switch Number 1)

The Alarm Relay is in Normal open mode. This switch is used to energize or de-energize the Alarm relay in normal mode.

1. Energize: Normal condition: contact close, Alarm condition: contact open.
2. De-energize: Normal condition: contact open, Alarm condition: contact close.

- Relay Fault Energize / De-energize (SW2 – Switch Number 2)

The Fault Relay is in Normal open mode. This switch is used to energize or de-energize the Fault relay in normal mode.

3. Energize: Normal condition: contact close, Fault condition: contact open.
4. De-energize: Normal condition: contact open, Fault condition: contact close.

- Reserved / Not Used (SW2 – Switch Number 3)

This switch has no assigned function and is reserved for future use. Changing the position of this switch does not affect the operation of the detector.

- Simulator Mode Enable / Disable (SW2 – Switch Number 4)

This switch is used to activate or deactivate the simulator mode. Simulator mode allows the use of an external simulator (SFD-1000-RS for IR4 & SFD-1000-US for UV/IR) for device simulation and testing without the presence of a real flame.

Mentioned adjustments will be done by Dipswitch SW2 according to Figure 1 and Table 4

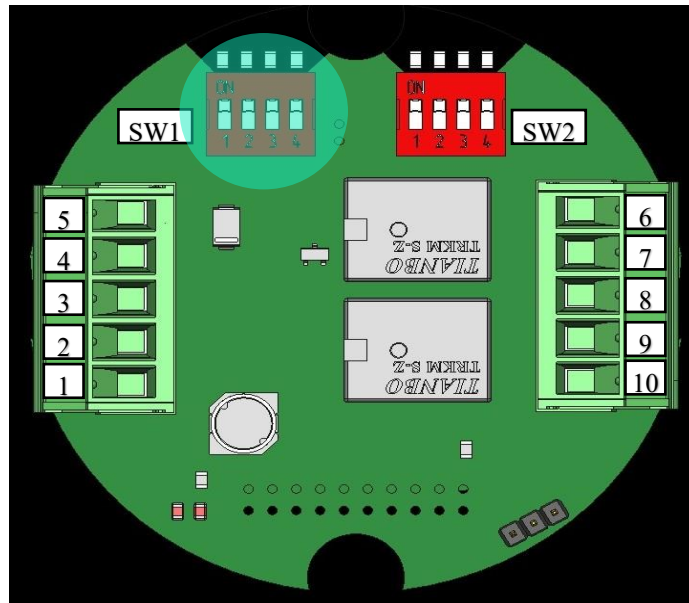

Figure 1 :Setting Adjustment Dip-switch location

Table 3: Setting Adjustment at Dipswitch SW1

Item	Description	Configuration	SW1	Switch Position	Factory configuration												
1	Sensitivity Level	Higher	1-2	ON <table border="1"><tr><td>1</td><td>2</td><td>3</td><td>4</td></tr><tr><td>■</td><td>■</td><td></td><td></td></tr><tr><td>OFF</td><td></td><td></td><td></td></tr></table>	1	2	3	4	■	■			OFF				Low
1		2		3	4												
■		■															
OFF																	
2	High	ON <table border="1"><tr><td>1</td><td>2</td><td>3</td><td>4</td></tr><tr><td></td><td>■</td><td></td><td></td></tr><tr><td>OFF</td><td>■</td><td></td><td></td></tr></table>	1	2	3	4		■			OFF	■					
1	2	3	4														
	■																
OFF	■																
3	Medium	ON <table border="1"><tr><td>1</td><td>2</td><td>3</td><td>4</td></tr><tr><td>■</td><td></td><td></td><td></td></tr><tr><td>OFF</td><td></td><td>■</td><td></td></tr></table>	1	2	3	4	■				OFF		■				
1	2	3	4														
■																	
OFF		■															
4	Low	ON <table border="1"><tr><td>1</td><td>2</td><td>3</td><td>4</td></tr><tr><td></td><td></td><td></td><td></td></tr><tr><td>OFF</td><td>■</td><td>■</td><td></td></tr></table>	1	2	3	4					OFF	■	■				
1	2	3	4														
OFF	■	■															
5	Alarm Latch	Latch	3	ON <table border="1"><tr><td>1</td><td>2</td><td>3</td><td>4</td></tr><tr><td></td><td></td><td>■</td><td></td></tr><tr><td>OFF</td><td></td><td></td><td></td></tr></table>	1	2	3	4			■		OFF				Latch
1		2		3	4												
		■															
OFF																	
6	Non-Latch	ON <table border="1"><tr><td>1</td><td>2</td><td>3</td><td>4</td></tr><tr><td></td><td></td><td></td><td>■</td></tr><tr><td>OFF</td><td></td><td></td><td>■</td></tr></table>	1	2	3	4				■	OFF			■			
1	2	3	4														
			■														
OFF			■														
7	BIT-Configuration	With BIT	4	ON <table border="1"><tr><td>1</td><td>2</td><td>3</td><td>4</td></tr><tr><td></td><td></td><td></td><td>■</td></tr><tr><td>OFF</td><td></td><td></td><td></td></tr></table>	1	2	3	4				■	OFF				With BIT
1		2		3	4												
			■														
OFF																	
8	With-out BIT	ON <table border="1"><tr><td>1</td><td>2</td><td>3</td><td>4</td></tr><tr><td></td><td></td><td></td><td></td></tr><tr><td>OFF</td><td></td><td></td><td>■</td></tr></table>	1	2	3	4					OFF			■			
1	2	3	4														
OFF			■														

Table 4: Setting Adjustment at Dipswitch SW2

Item	Description	Configuration	SW2	Switch Position	Factory configuration												
1	Relay- Configuration	AL_REL En	1	ON <table border="1" style="display: inline-table; vertical-align: middle;"><tr><td>1</td><td>2</td><td>3</td><td>4</td></tr><tr><td style="background-color: black;"></td><td></td><td></td><td></td></tr><tr><td>OFF</td><td></td><td></td><td></td></tr></table>	1	2	3	4					OFF				OFF
1		2		3	4												
OFF																	
2	AL_REL DEn	ON <table border="1" style="display: inline-table; vertical-align: middle;"><tr><td>1</td><td>2</td><td>3</td><td>4</td></tr><tr><td></td><td style="background-color: black;"></td><td></td><td></td></tr><tr><td>OFF</td><td></td><td></td><td></td></tr></table>	1	2	3	4					OFF						
1	2	3	4														
OFF																	
3	FT_REL En	2	ON <table border="1" style="display: inline-table; vertical-align: middle;"><tr><td>1</td><td>2</td><td>3</td><td>4</td></tr><tr><td></td><td style="background-color: black;"></td><td></td><td></td></tr><tr><td>OFF</td><td></td><td></td><td></td></tr></table>	1	2	3	4					OFF				ON	
1	2		3	4													
OFF																	
4	FT_REL DEn	ON <table border="1" style="display: inline-table; vertical-align: middle;"><tr><td>1</td><td>2</td><td>3</td><td>4</td></tr><tr><td></td><td></td><td style="background-color: black;"></td><td></td></tr><tr><td>OFF</td><td></td><td></td><td></td></tr></table>	1	2	3	4					OFF						
1	2	3	4														
OFF																	
5	Free Switch	...	3	ON <table border="1" style="display: inline-table; vertical-align: middle;"><tr><td>1</td><td>2</td><td>3</td><td>4</td></tr><tr><td></td><td></td><td></td><td style="background-color: black;"></td></tr><tr><td>OFF</td><td></td><td></td><td></td></tr></table>	1	2	3	4					OFF				OFF
1	2	3	4														
OFF																	
6	SIM- Configuration	With SIM	4	ON <table border="1" style="display: inline-table; vertical-align: middle;"><tr><td>1</td><td>2</td><td>3</td><td>4</td></tr><tr><td></td><td></td><td></td><td style="background-color: black;"></td></tr><tr><td>OFF</td><td></td><td></td><td></td></tr></table>	1	2	3	4					OFF				OFF
1		2		3	4												
OFF																	
7	With-out SIM	ON <table border="1" style="display: inline-table; vertical-align: middle;"><tr><td>1</td><td>2</td><td>3</td><td>4</td></tr><tr><td></td><td></td><td></td><td style="background-color: black;"></td></tr><tr><td>OFF</td><td></td><td></td><td></td></tr></table>	1	2	3	4					OFF						
1	2	3	4														
OFF																	

8 Installation instruction

Installing the flame detector on site or opening or operating the cover of the installed flame detector should only be done by an approved user or our company's installation and repair person. Failure to do so may cause fire, explosion, or other serious personal injury and property damage. Also, please work only after checking the presence of residual explosive gases or flammable materials around and disconnecting the power supply.

8.1 Swivel Mounting Bracket Installation

According to the type of mounting bracket and its ability to be adjusted in different directions (horizontal and vertical angles), it is possible to install the detector on the ceiling, wall, and on the two-inch pipe.

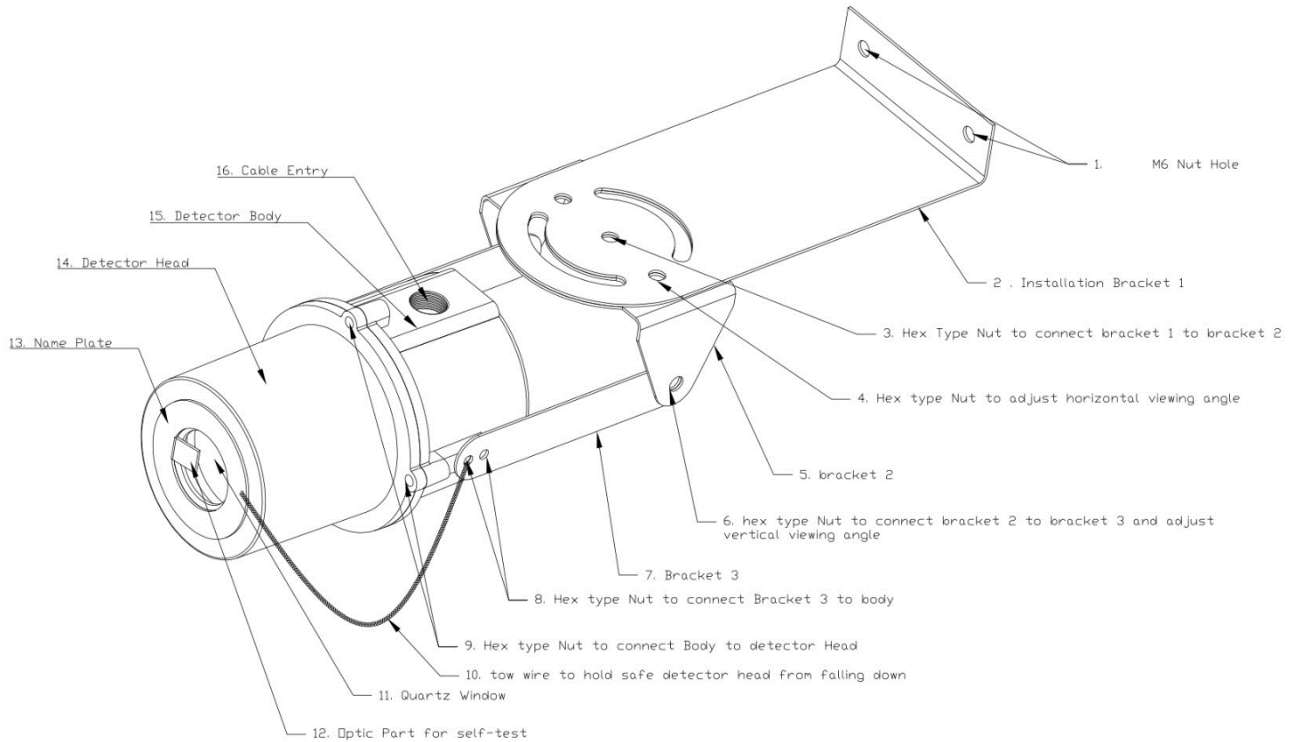

Figure 2: Outline drawing and detector parts

In case of installation at the ceiling, remove bracket 1 and use brackets 2 and 3.

In case of installation on the wall or 2-inch pipe, use M6 U-Bolt (Item 1-Figure 2)

8.2 Installing Detector on Swivel Mounting Bracket

According to Figure 2, the detector body is connected to the adjustable base by bracket 3 (Item 7) and to the detector body by two M5 screws (Item 8).

8.3 Opening Detector Head

After installing the gland and placing the cable from Item 16 in figure 2 (it is possible to install the gland in two directions up and down), in order to wire the detector, according to figure 2, open four M6 screws (item 9) with an Allen key and the Detector Head section (Item 14) is separated from the body. It is necessary to explain that in order to prevent damage or falling from a height, Detector Head is connected to Detector Body (Item 15) by a towing wire (Item 10). (Before opening the Detector Head, make sure there is a towing wire.)

Then according to paragraph 10, the required wiring is done.

8.4 Closing Detector Head

After wiring the detector, the Detector Head is connected to the Detector Body and four M6 screws (Item 9) are closed with an Allen wrench.

8.5 Adjusting Viewing Angle

The angle of the detector can be adjusted in both horizontal and vertical axes.

If you need to adjust the tilt in the horizontal axis, use screws No. 3 and 4 according to Figure 2.

If you need to adjust the tilt in the vertical axis, according to Figure 2, use screws No. 6 on both sides of the detector.

9 Input and Output Terminals

The SFD-1000 flame detector has Analog 0-20 mA and Relay Contact outputs, and the input and output terminals can be used as described in Figure 3 and Table 4.

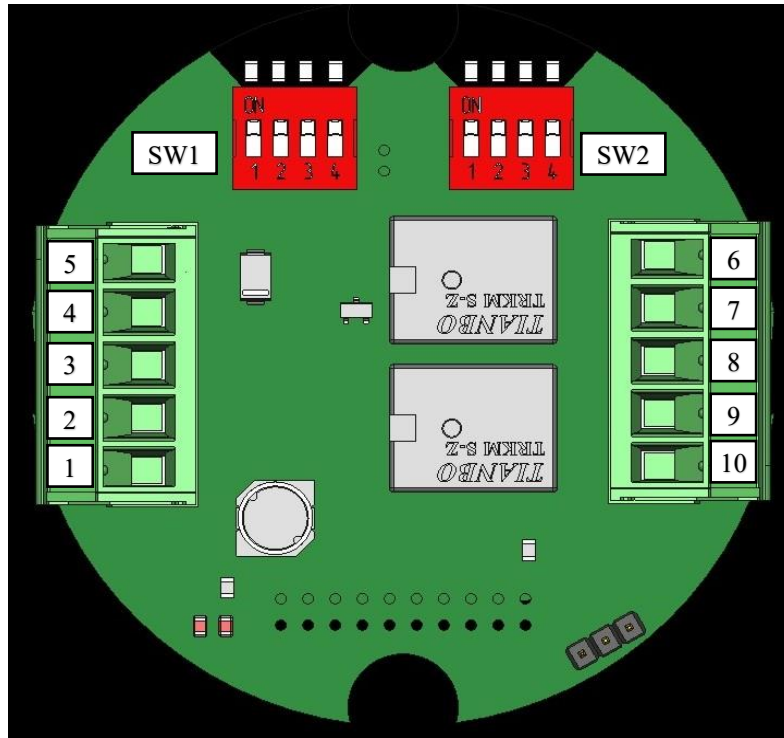

Figure 3: Terminals Arrangement and their numbering

Table 4: Terminals and their numbering

Item	Configuration	Description
1	V+	Positive Voltage Input (24 VDC)
2	V-	Negative Voltage Input (0)
3	mA	0-20 mA Current Output
4	485-A	RS485 Positive Signal (only for manufacturer)
5	485-B	RS485 Negative Signal (only for manufacturer)
6	ALA	Alarm Relay Common Connection Output
7	ALB	Alarm Relay Normally Open Connection Output
8	TRBA	Fault Relay Common Connection Output
9	TRBB	Fault Relay Normally Open Connection Output
10	-	Not used

10 Wiring Diagrams

The SFD-1000 flame detector has Analog 0-20 mA and Relay Contact outputs, and can be used as described as follow:

10.1 Using Relays Wiring Diagram

In order to use the relay outputs in accordance with Figure 4, you can use pins 6 and 7 of the Alarm (AL) relay to display the Alarm Condition and pins 8 and 9 of the TRB relay to display the Fault Condition state. Keep in mind that in this case, the detector needs to be connected to the power supply in pins 1 (V+ or 24 VDC) and 2 (V- or 0).

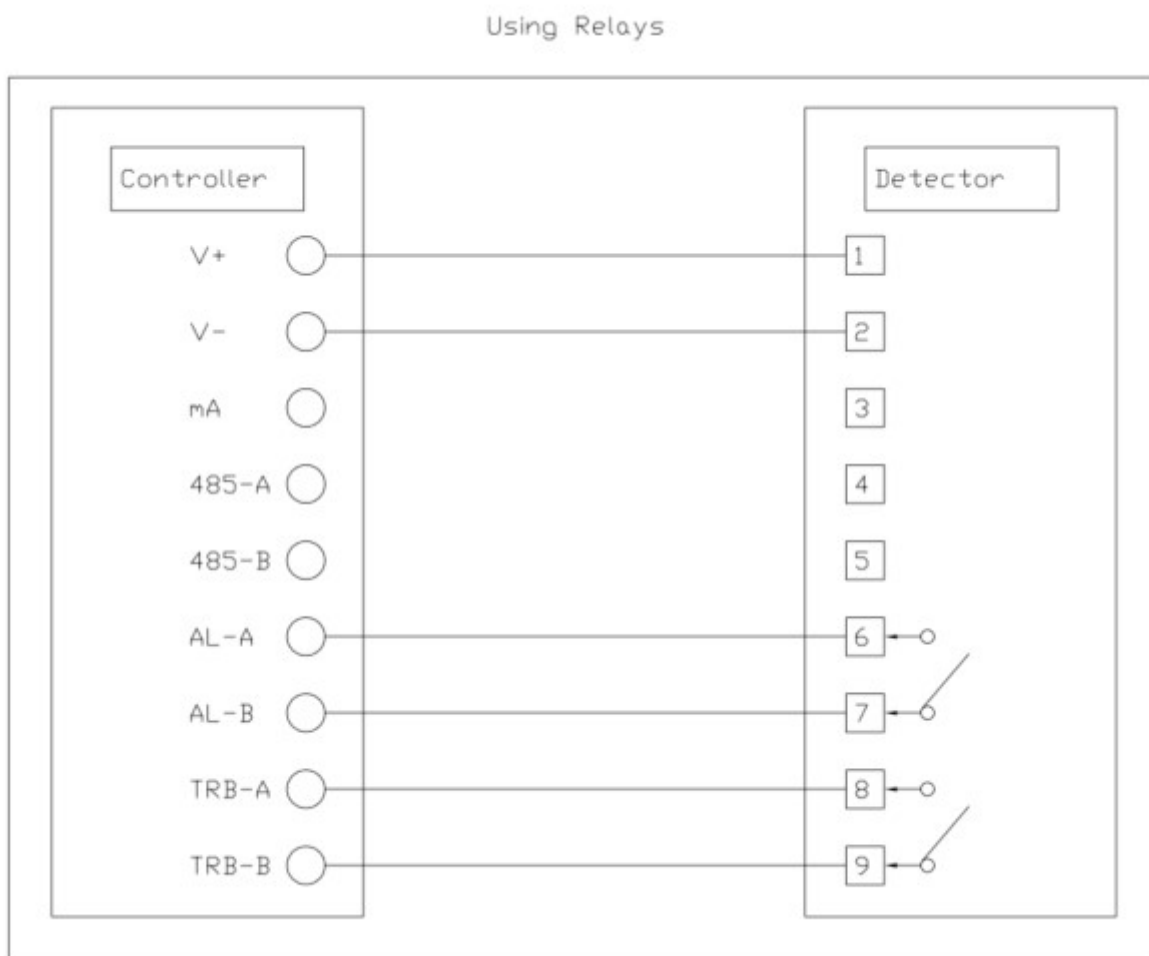

Figure 4: Using Relay Contact Wiring Diagram

10.2 Using Analog Output Wiring Diagram

In order to use the analog output, according to Figure 5, you can use pins 1 (V+ or 24 VDC), 2 (V- or 0) and pin 3 (mA).

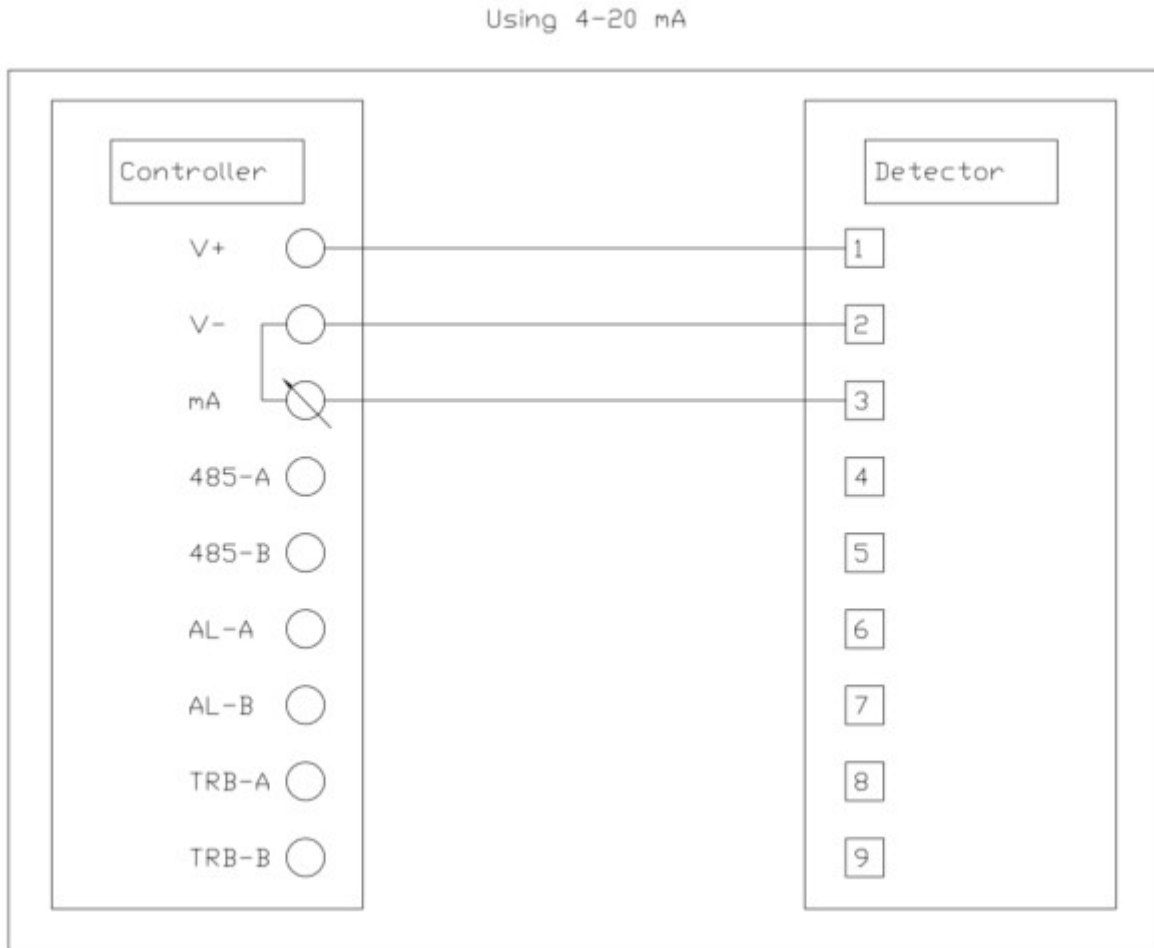

Figure 5: Using 4-20 mA Analog output

11 Drawings and Dimensions

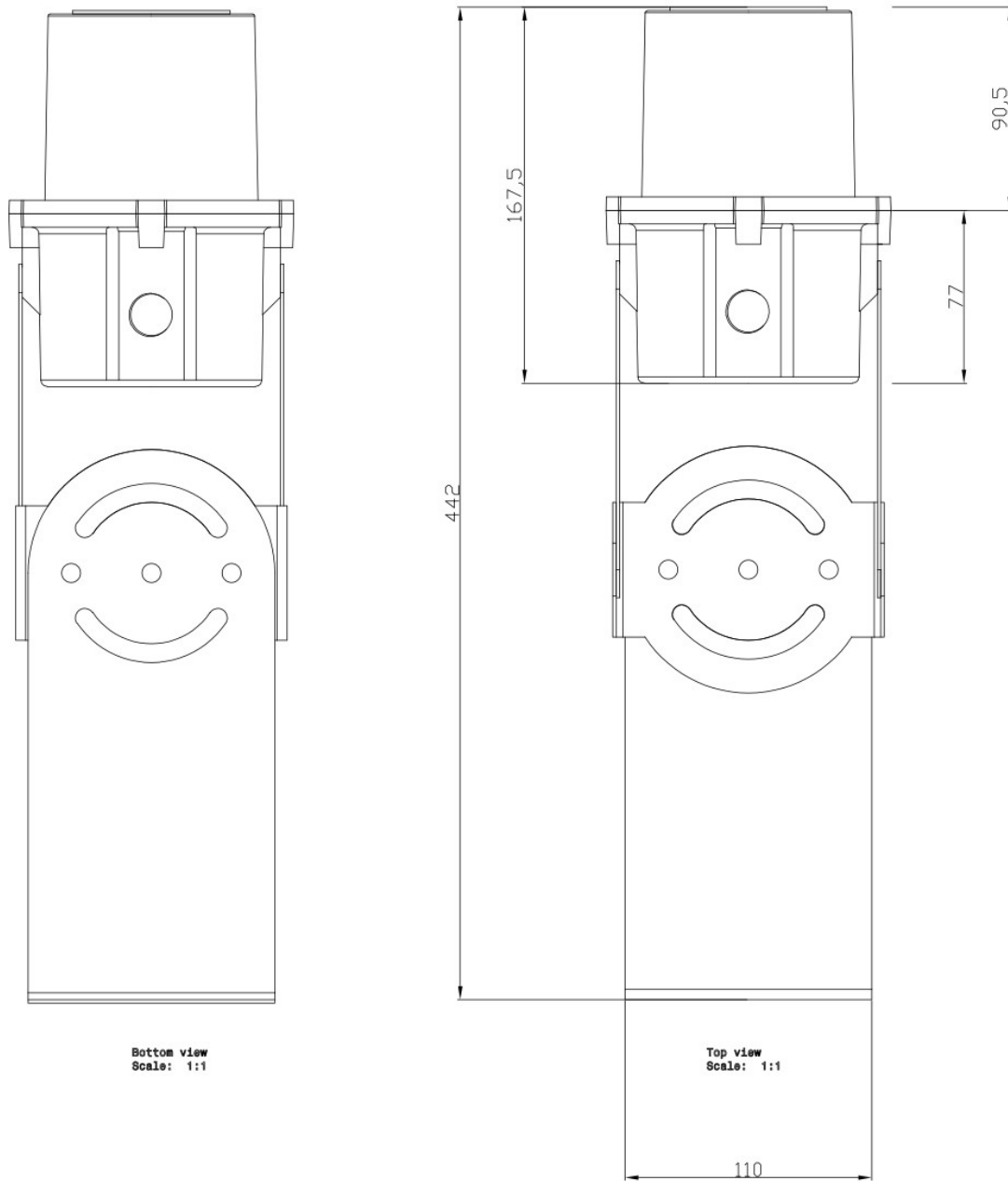
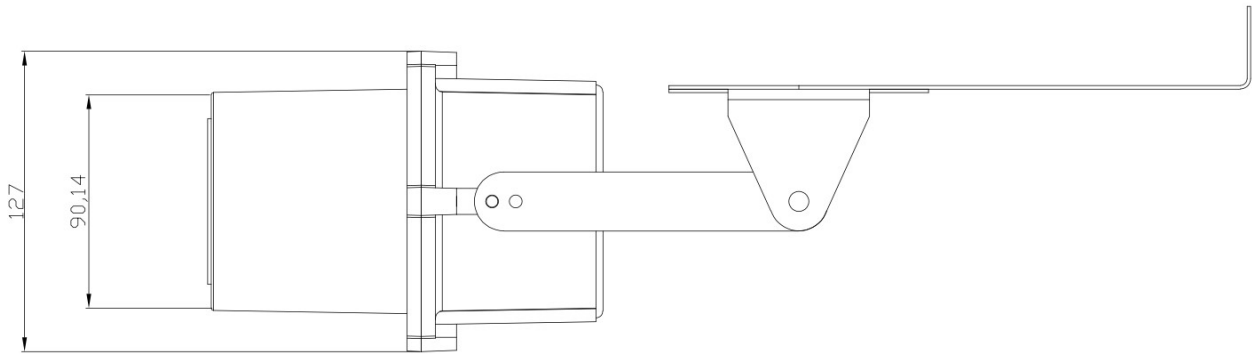
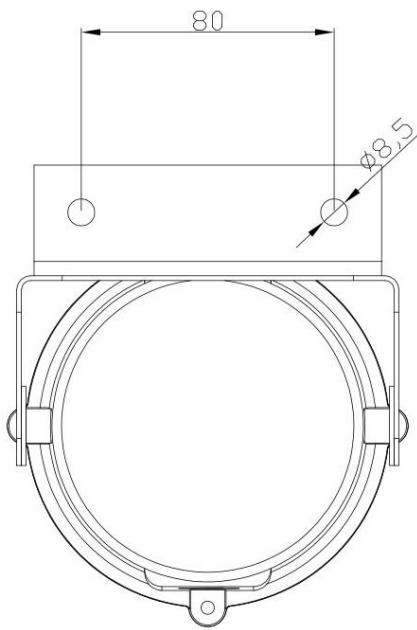

Figure 6: Detector top and bottom view



Right view
Scale: 1:1

Figure 7: Detector Right View



Rear view
Scale: 1:1

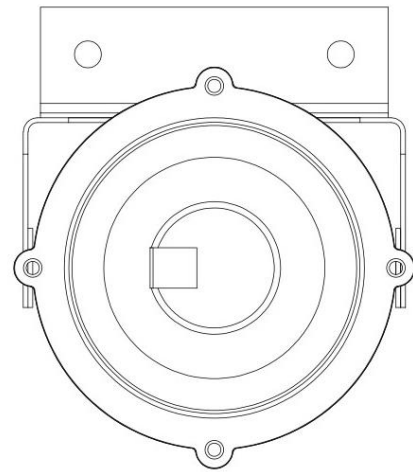

Front view
Scale: 1:1

Figure 8: Detector Front and Rear View

12 Functional Safety Cautions

12.1 Simin Gaman Aria Flame Detectors

The flame detector series SFD-1000 fulfils the requirement of the IEC 61508 for Safety Integrity Level (SIL) 2 considering clauses 12.2 to 12.

12.2 Certified product identification of device

Kind of Products:	Infra-red and Ultraviolet flame detector series
Type Designation:	ATEX (II 2G Ex db IIC T6 Gb)
Max. Power Consumption:	10.8 W
Max. Current:	450 mA
Output:	0-20 mA
Useful lifetime:	10 Years

12.3 Applied Standards

IEC 61508 Part 1-7:2010

Functional Safety of E/E/PE safety Related System

EN 54-10: 2002 and EN 54-10/A1:2005

Fire Detection and fire alarm systems

Part 10: Flame Detectors-point detectors

EN 50130-4:2011 (EMC)

No.	Description
1	Electrostatic discharge (operational)
2	Radiated electromagnetic fields (operational)
3	Conducted disturbances induced by electromagnetic fields (operational)
4	Fast transient bursts (operational)
5	Slow high energy voltage surge (operational)

12.4 Safety Parameters

Safety Function:

The Safety Function of the flame detector series SFD-1000 is defined by detect flames in which carbon dioxide (CO₂) is produced in combustion process and announces this over 4-20 mA analog output.

Characteristics as per IEC 61508-2010:

SIL	2
HFT (Intern)	0
Device Type	B
Mode of Operation	Low Demand
Average ambient temperature	Max: 60 °C
Mean Time to repair	0 h
Proof-test Interval	365 days

Safety Relevant Parameters

Parameter	For SU (UV/IR)
λ_S (FIT)	2271.1234
λ_D (FIT)	7520.3318
λ_{DU} (FIT)	280.75
λ_{DD} (FIT)	7239.5817
SFF	97.13
DC	96.26%
PFD _{avg} (1oo1)	1.23×10^{-3}
PFD% _{SIL2}	12.29%
PFD _{avg} (1oo2)	2×10^{-6}
PFD% _{SIL3}	0.02%

Remarks:

- Failure rates of the electronic components as per Siemens SN 29500, calculated based upon an ambient temperature of 60 °C and statistical data of the sensor elements
- The calculation was performed based on a proof-test interval T1 = 365 days

12.5 Guidelines for configuring, installing, operating and service

The alert conditions according to SIL 2 is implemented by Alert signal via 20 mA current loop.

12.6 Conditions for Safe Operation

1. The flame detector shall consist only of the approved hardware and software modules.
 - Software Version: 0001

- Hardware Version: 0001

2. The 24 V power supply must fulfill the requirements for PELV/SELV of EN 60950.
3. The automatic BIT (built-in test) must be activated.

Using the 0-20 mA Interface for Alerting:

The following parameters shall be set:

- Automatic Built-in test: On
- Connected to 0-20 mA terminals

The following allowed output current must be supervised with an accuracy of ± 5 percent.

- Normal State: 4 mA
- Alarm State: 20 mA

The 0-20 mA can be used as low demand mode.

The receiving device must be programmed to indicate a fault condition when current levels reach overcurrent or undercurrent.

Other:

- The complete function of the flame detector (Proof test, function of the 0-20 mA interface) must be examined every six or twelve months, or whenever the flame detector must be switched off and on.
- The HART, RS-485 interfaces and Relays must not be used for the transmission of the safety-related data.

12.7 Proof Test Procedure and Special Tools

According to clause 6.2 proof test procedure shall be done based on following:

- 1- Input power of detector shall be measured, acceptance criteria is 18 to 30 VDC.
- 2- Current of detector at normal condition shall be measured, acceptance criteria are 4 mA \pm 0.24 mA
- 3- From distance of 2 to 3 meters flame simulator will be powered on, during time of flame simulator is powered on, Detector shall go to alarm status and current shall be measured, acceptance criteria are 20 mA \pm 0.4 mA
- 4- Detector shall be rested by de-energized and energize of 24 VDC power.

Proof Test Special Tools:

- Flame Simulator

12.8 Cleaning Procedure

Cleaning The detector must be kept as clean as possible. Clean the viewing window and the reflector of the flame detector periodically. The frequency of cleaning operations depends upon the local environmental conditions and specific applications. The fire detection system designer will give his recommendations. To clean the detector viewing window and reflector:

- 1 Disconnect power to the detector before proceeding with any maintenance including window/lens cleaning.
- 2 Use water and detergent, and then rinse the viewing window with clean water.
- 3 Where dust, dirt, or moisture accumulates on the window, first clean with a soft optical cloth and detergent only, and then rinse with clean water.

12.9 Fault/failure action plan

If proof-testing fails, record and document the result in the relevant log book and replace the detector to restore the system to the necessary safety level.

12.10 Product repair

Other than the standard cleaning actions described in the SFD-1000 Manual, there are no serviceable parts in the SFD-1000. Therefore, if the device fails, you must send it back to Simin Gaman Aria for failure analysis.

If you need to repair hardware, purchase all spare parts from Simin Gaman Aria. Consult Simin Gaman Aria Customer Care for additional information.

12.11 Decommissioning and disposal

Procedure

When the detector has reached the end of its life, decommission and dispose of it in a safe way and in accordance with local regulations.

Simin Gaman Aria encourages customers to dispose of the detectors in a sustainable way to allow a high degree of recycling.

12.12 Vocabulary table of IEC61508

Item	Description
SIL	Safety Integrity Level
HFT	Hardware Fault Tolerance
λ_S (FIT)	the number of safe of spurious failures per unit time for a piece of equipment.
λ_D (FIT)	the number of dangerous of spurious failures per unit time for a piece of equipment.
λ_{DU} (FIT)	the number of undetected dangerous of spurious failures per unit time for a piece of equipment.
λ_{DD} (FIT)	the number of detected dangerous of spurious failures per unit time for a piece of equipment.
SFF	Safe failure fraction
DC	Diagnostic coverage
PFDavg	the average Probability of Failure on Demand